

RoboCup Rescue 2022 Team Description Paper

SHINOBI

Yuki Morimoto, Takashi Tomiyama, and Ryohei Michikawa

Info

Team Name: SHINOBI
 Team Institution: Matsuno Lab, Kyoto University
 Team Leader: Ryohei Michikawa
 Team URL: <http://www.mechatronics.me.kyoto-u.ac.jp/>
 Videos of our robot doing tests:
<https://youtu.be/1f8eYYa2CPg>
<https://youtu.be/-HCrKGjENzQ>
<https://youtu.be/jx-RC282g1w>

RoboCup Rescue 2022 TDP collection:
https://robocup-rescue.github.io/team_description_papers/

Abstract—This paper explains details of the robot FUHGA3 which was designed to participate in RoboCup 2022 competition. The SHINOBI rescue robotics team consists of students that are studying in Matsuno Laboratory, Kyoto University, Japan.

Index Terms—RoboCup Rescue, Team Description Paper, SHINOBI, FUHGA3.

I. INTRODUCTION

THE SHINOBI rescue robotics team consists of Doctor and Master’s degree students that are studying in Matsuno Laboratory, Kyoto University, Japan and Tadokoro Laboratory’s Tadakuma team, Tohoku University, Japan. It consists of ten members. SHINOBI has developed several robots in the past and tested its robots in both real disaster areas and competitions.

- RoboCup 2002 (Japan,Korea) : 2nd
- RoboCup 2004 (Portugal) : 5th
- Robocup 2005 (Japan) : Best Design Award / Advanced Mobility 2nd
- RoboCup 2006 (German) : Rescue Robot League Locomotion Challenge 1st
- RoboCup 2007 (USA-Atlanta) : Locomotion Challenge 2nd
- Robocup 2009 (Austria) : 4th /Best In Class Mobility 3th
- World Robot Summit 2018 (Japan) : STM 1st place
- Robocup 2019 (Australia-Sydney) : 1st place / Best in class dexterity
- Robocup 2020 (Online) : Best in Class Search and Inspect / Autonomous Mobility
- World Robot Summit 2020 (Japan-Fukushima) : 2nd place

SHINOBI’s previous robots have been innovative in the area of rescue robotics. For example FUHGA is a robot that has

two body crawlers, two flippers and a six degrees of freedom manipulator. The concept of FUHGA is “high mobility”. To achieve this, we mainly focused on two characteristics; arm and full body sponge crawler. PIAP GRYF [1] is an explosive ordnance disposal robot, which is characterized by its manoeuvrability. Because of its light body and relatively large arm, the robot can overcome the step higher than its height using its arm. However, PIAP GRYF’s main body is not fully covered by body crawler. This may cause it to get stuck in uneven fields. Full body crawler is known to have good performance for traverse rough terrain, since the crawler can touch to the ground. Now, a rescue robot called Quince [2] which has body crawlers, is used for inspection of nuclear power plants after Great East Japan Earthquake. For our robot, we designed a strong arm with a passive wheel to help mobility and full body sponge crawler for better travelling performance. In addition, we use sponge for crawler rather than rubber. Sponge can adaptively fit to obstacles and rough terrains and increases the traction.

The aim of the SHINOBI team for this competition is to build a robot, FUHGA3 that can be both tele-operated and autonomous, that can be used for search and rescue missions, has higher mobility than FUHGA/FUHGA2 and good understanding of its environment. The main tasks were to make the robot durable and modular in the sense that it can move in many different terrains, good manipulation ability and was to generate a map of its environment and understanding the dangers around it. To achieve these tasks, the robot has been equipped with several sensors and the mechanical design was built accordingly. The sensors for understanding the environment are: cameras, CO2 sensor, thermal camera. The mechanics of the robot consists of three categories. One is the mobility. Two people from the SHINOBI Team has been assigned to design the mobility. The aim of the Mobility Team was to make the main body of the robot highly mobile, as light as possible and very durable. The robot has four flippers and two body crawlers to move. The second category was the Arm. The Arm group consisted of three people and their task was to build the lighter manipulator than the manipulator of FUHGA/FUHGA2. The arm team has built a six degrees of freedom manipulator. The third category was the gripper. The gripper team was to make a gripper to be attached to it as an end-effector.

In conclusion, SHINOBI Team has built a robot that has high mobility and has a good sense of its environment. Over ten years, SHINOBI Team has the experience of building rescue robots caring for real disasters. This experience helped us predict the possible problems beforehand and helped us



Fig. 1. Photo of the our robot, FUHGA3!!.

avoid unexpected results. We have been inspired with our previous robots and integrated our new ideas into the new robot FUHGA3.

II. SYSTEM DESCRIPTION

A. Hardware

The hardware structure is shown in Fig 1.

- **Locomotion**
FUHGA3 has high mobility thanks to its body crawlers and flippers. Each body crawler driven by a DC motor (Maxon, 24V, 200W) is approximately 520 mm in width, which reduces the possibility of getting stuck. They are made of sponge that makes FUHGA3 robust against impacts. The 4 flippers will help overcoming obstacles. Now, we have made flippers longer, so that FUHGA3 can overcome larger obstacles. The flipper angle is driven by a powerful servo motor on each flipper (Dynamixel, 24V, 200W).
- **Manipulation**
In order to manipulate objects, FUHGA3 has a jamming gripper which are generated by Tohoku Univ. By using this, FUHGA3 can grasp many kind of objects. Links are created by CFRP, so it is enough hard to work in rescue field.

B. Software

Refer to Table IV in the Appendix.

Both the PC installed in the robot and the PC of the operator station use Ubuntu 16.04.

Meanwhile, ROS Kinetic is used as to manage the messages of sensors and controllers. MCUs are installed in each module on the robot, and each MCU performs local processing. For example, the MCU on the motor driver unit acquires and processes sensor values from the encoder and potentiometer, and controls so that the angular velocity of the motor converges to the target value. Based on information gathered from each module and device, the main PC in the robot creates a 3D CG

model of the robot and a 3D map. The manipulator calculates and controls the joint angle that realizes the target position of the gripper using inverse kinematics.

C. Communication

Communication between the operator station and robot is done using wireless LAN. For this communication, Tp-Link Archer C3150 and RE650 which are radio equipments conforming to IEEE 802.11ac/n/a has been used. Archer C3150 is used for the master unit antenna, and RE650 is used for the slave unit antenna.

D. Human-Robot Interface

To input tele-operation DELL Inspiron and touch screen are used. Three or four fisheye cameras are mounted on the robot, and operators can switch images to be displayed larger if necessary. Since the position of the tip of the manipulator is controlled by inverse kinematics, the operator can operate with intuitive input. We create a 3D map with SLAM using Intel RealSense Depth Camera and UST-20LX-H01, and display it for remote operation. The 3DCG model reflecting the posture of the robot, the angle of the flipper, and each joint angle of the arm is displayed. It also displays information on thermal camera, microphone, and CO2 sensor.

To get used to the robot, the operator conducted basic training of manoeuvring using simulations and then practised using real machine. In particular, we practised by reproducing slalom, stairway, and random step environments.

III. APPLICATION

A. Set-up and Break-Down

In order to shorten the time of Set-up and Break-Down, we put together a laptop PC, sub display, game pad, antenna etc in one case. You can build an operator station by carrying a single case and opening it.

B. Mission Strategy

The strategy for this year was mostly about the mechanical design of the robot. We designed a robot that has high mobility by using CFRP.

C. Experiments

We have tested the robot's mobility on smooth surfaces, random step, and stairs. We have tested the robot's manipulation by grasping two types valves. We have learned from our test that rigidity is important to manipulate something accurately.

D. Application in the Field

We have developed several rescue robots previously and some of them have been used for inspection in buildings affected by huge earthquakes. We have gathered information from disaster areas which were too dangerous for humans to enter. Our new robot, FUHGA3, has higher performance in mobility than our previous ones due to the fact explained above. Therefore, we believe that FUHGA3 will be more useful in disaster-affected areas. We will improve our robot for better use by improving gripper, changing or adding robot parts for better sandproofing.

IV. CONCLUSION

In conclusion, as a team with a background of more than 10 years, we believe that we have built a robot that is better than previous ones in the case of mobility and sensing its environment. Learning from previous experiences, failures and talking to previous members of the SHINOBI, we had a good understanding of what to do from the beginning and we worked hard for it. Until now, we still have not finished the whole robot. We still have improvements to do about SLAM, programming, manipulation and designing the robot. After these improvements, robot will be ready to compete in RoboCup 2022. This is also the reason for the lack of detailed experiments. Therefore, we would like to work hard and finish the robot as soon as possible.

APPENDIX A

TEAM MEMBERS AND THEIR CONTRIBUTIONS

- Tatsuya Takemori programming, electronics, control, manipulator design, operator
- Xixun Wang interface, sensors
- Ryohei Michikawa mobility design, team leader
- Yushi Okuda mobility design
- Takashi Tomiyama manipulator design
- Takumi Shibuya communication, interface
- Yuki Morimoto manipulator design

APPENDIX B

CAD DRAWINGS

Please see Fig. 2 and 3.

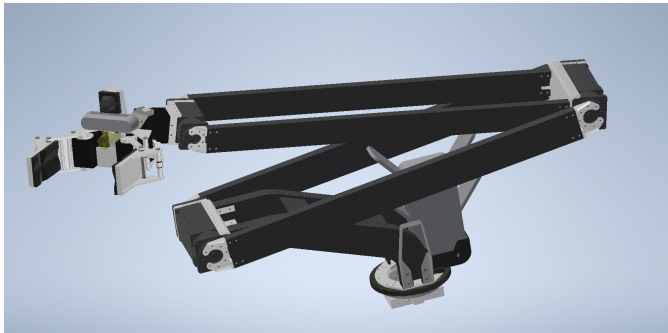

Fig. 2. The manipulator of FUHGA3 consists of arm and gripper

APPENDIX C

LISTS

A. Systems List

For hardware list, please refer to Table I, II.

B. Hardware Components List

For hardware list, please refer to Table III.

C. Software List

For software list, please refer to Table IV.

TABLE I
MANIPULATION SYSTEM

Attribute	Value
Name	FUHGA3
Locomotion	tracked
System Weight	40kg
Weight including transportation case	?
Transportation size	0.7 x 0.5 x 0.4 m
Typical operation size	1.0 x 0.5 x 1 m
Unpack and assembly time	30 min
Startup time (off to full operation)	10 min
Power consumption (idle/ typical/ max)	? / ? / ? W
Battery endurance (idle/ normal/ heavy load)	45 / 30 / 15 min
Maximum speed (flat/ outdoor/ rubble pile)	2 / 1 / - m/s
Payload (typical, maximum)	/ ? kg
Arm: maximum operation height	150 cm
Arm: payload at full extend	2kg
Support: set of bat. chargers total weight	1.3kg
Support: set of bat. chargers power	500W (10.5-29V DC)
Support: Charge time batteries (80%/ 100%)	? / 150 min
Support: Additional set of batteries weight	? kg
Any other interesting attribute	?
Cost	4,800,000 Yen

TABLE II
OPERATOR STATION

Attribute	Value
Name	FUHGA3-OP
System Weight	5kg
Weight including transportation case	?kg
Transportation size	?m
Typical operation size	0.5 x 0.4 x 0.4 m
Unpack and assembly time	1 min
Startup time (off to full operation)	1 min
Power consumption (idle/ typical/ max)	? / ? / ? W
Battery endurance (idle/ normal/ heavy load)	? / ? / ? h
Any other interesting attribute	?
Cost	2,500 USD

TABLE III
HARDWARE COMPONENTS LIST

Component	Brand&Model	Unit Price(USD)	Num.
Drive motors	Maxon RE50 200W	1,200	2
Drive gears	Maxon Planetary Gearhead GP52C	?	2
Drive encoders	Maxon Encoder HEDS 5540	?	2
Flipper motor	Dynamixel H54-200-S500-R	2,800	4
Shoulder motors	H54-200-S500-R	?	1
Shoulder, elbow motors	H54-200-S500-R	?	2
Batteries	Energizer (XP18000)	?	1
Batteries	LiPo (25.9 Volt 6500C)	?	1
Computing Unit	ZOTAC, ZBOX-MI549NANO	?	1
WiFi Adapter	Operator ? TP-Link Archer C3150	?	1
IMU	?	?	?
Cameras	?	?	?
infrared Cameras	?	?	?
CO ₂ Sensor	?	?	1
Battery Chargers	EOS 720	?	1

TABLE IV
SOFTWARE LIST

Name	Version	License	Usage
Ubuntu	16.04	open	
ROS	Kinetic	BSD	
OpenCV	2.4.10	BSD	Haar: Victim detection
Application for FUHGA3	1.0	closed source	

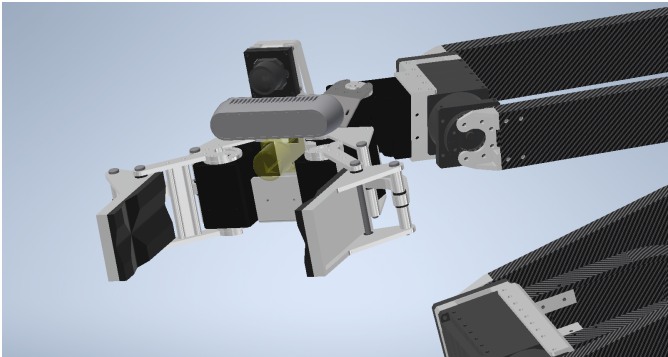

Fig. 3. The hand has 3-DoF wrist and fingers actuated with parallel-link mechanism. The gripper is jamming gripper created by Tohoku Univ.

ACKNOWLEDGMENT

The authors would like to thank machine shop of Kyoto University Katsura Campus for their help in machining the parts we need. We also would like to thank the previous members of SHINOBI Team.

REFERENCES

- [1] PIAP, <http://www.antiterrorism.eu/>
- [2] Keiji Nagatani, S. Kiribayashi, Y. Okada, et al., "Redesign of rescue mobile robot Quince," *Proc. IEEE Int. Symp. Safety, Security Rescue Robot.*, 2011.
- [3] Tetsushi Kamegawa, T. Yamasaki, H. Igarashi and F. Matsuno, "Development of the Snake-Like Robot "KOHGA"," *Proc. IEEE Int. Conf. on Robotics & Automation.*, 2004.